

# Ocean Controls KTA-261, 262 and 263 Micro-Stepping Bipolar Stepper Motor Drivers

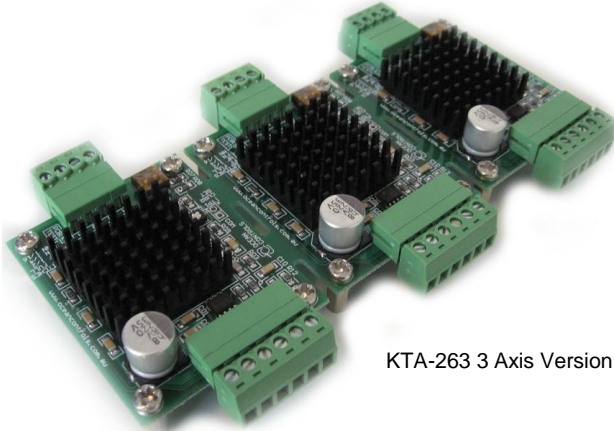

KTA-263 3 Axis Version Shown

- Controls Motors up to 2.5A
- Accepts up to 30VDC
- Full, Half, 1/4 and 1/16 Micro-Step Modes
- Internal Over Temp Protection
- Plug in Connectors
- Small Form from 58<sub>L</sub> x 47<sub>W</sub> x 31<sub>H</sub> mm
- Up to 3 Drives Per Board (Great for CNC)

The KTA-261, 262 and 263 are Bipolar Stepper Motor Drivers capable of controlling 4, 6 and 8 wire stepper motors at up to 2.5A. As well as full stepping, half, quarter and sixteenth micro-step modes are available, giving 200, 400, 800 or 3200 steps per revolution for standard 1.8° degree motors. KTA-261 is capable of controlling 1 motor, KTA-262 up to 2 motors and KTA-263 up to 3 motors. Only two control signals are required to operate the driver, being the Step signal and the Direction signal. Version 2 circuit board now includes an Enable signal, if you are not using the enable line connect the pin to the COM terminal

### Connections:

Name	Description
V+	Power Supply Input (30V max)
COM	Common Ground Connection
STP	Step Input
COM	Common Ground Connection
DIR	Direction Input
ENA	Enable Input (Connect to COM to enable driver)
A	Motor Coil A Connection 1
B	Motor Coil B Connection 1
/B	Motor Coil B Connection 2
/A	Motor Coil A Connection 2

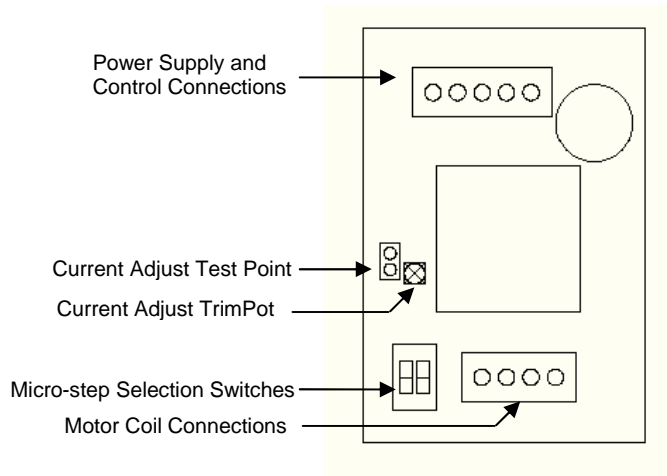

### Input Signals

Input signals required to operate the controller are the Enable (ENA), Step (STP) and Direction (DIR) signals. The Enable signal must be connected to COM to enable the motor, when disconnected the motor will not be powered, this can come from a controller or be connected directly to the COM terminal. Pulses on the Step input will make the motor step one micro-step, at the resolution determined by the DIL switches, while the Direction input controls the direction the motor will turn for that step. A High signal is defined by a voltage above 3.5V and a Low signal is defined by a voltage below 1.5V.

For KTA-262 and KTA-263 boards, power supply connections must be made for each individual driver as the drivers are not electrically connected.

### Micro-step Resolution

Micro-step Resolution is easily set using the DIL Switch next to the motor connections.

SW1	SW2	Mode	Steps/Rev (1.8° Motor)	Resolution (1.8° Motor)	Max Coil Current
OFF	OFF	Full Step	200	1.8°	2.0A
ON	OFF	1/2	400	0.9°	2.5A
OFF	ON	1/4	800	0.45°	2.5A
ON	ON	1/16	3200	0.1125°	2.5A

**Motor Current**

Motor current is set using a multimeter to measure the voltage at TP1 and adjusted using the TrimPot P1 located near the edge of the board (see Fig 1). For full stepping the maximum current is 2A, this is when the TP1 voltage is 4V and for other stepping modes the maximum current is 2.5A at the TP1 voltage of 4V. The voltage required for a given coil current is calculated with

$$2 \times I_{Coil}(A) = V_{TP1} \text{ for full stepping and,}$$

$$1.6 \times I_{Coil}(A) = V_{TP1} \text{ for all other stepping modes.}$$

The following table can be used as a guide:

Current (A)	Full Step $V_{TP1}(V)$	1/2, 1/4, 1/16 Step $V_{TP1}(V)$
2.50	N/A	4.0
2.25	N/A	3.6
2.00	4.0	3.2
1.75	3.5	2.8
1.50	3.0	2.4
1.25	2.5	2.0
1.00	2.0	1.6
0.75	1.5	1.2
0.50	1.0	0.8

**Motor Wiring:**

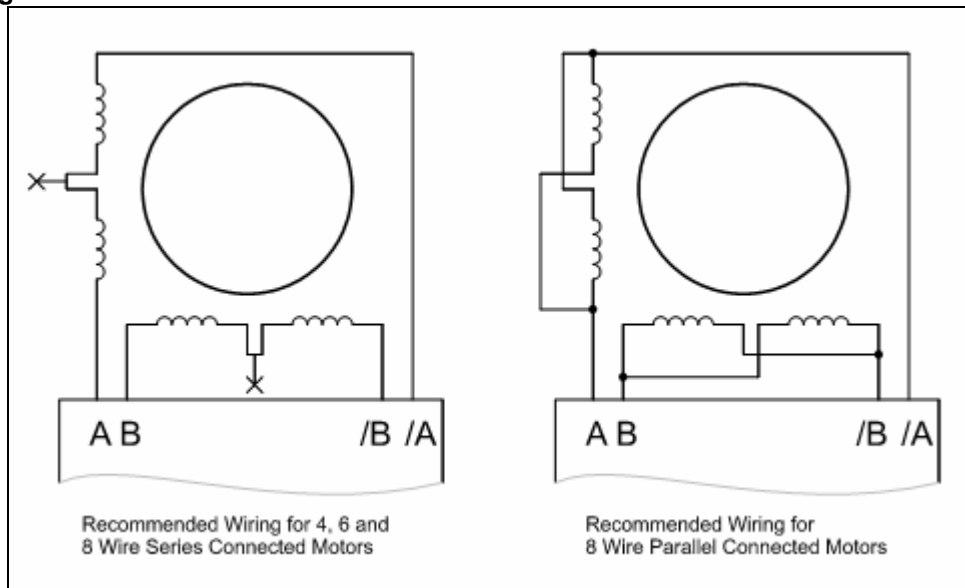

Connecting 8 wire motors in the parallel configuration gives increased torque and speed at the cost of increased current consumption.

**Warnings:**

There is no reverse polarity detection in the driver. Power positive must be connected to V+ and negative to COM.

The absolute maximum voltage the driver can withstand is 35V. Ensure that supply voltage stays at or below 30VDC as motor back EMF can raise the voltage.

Do not connect or disconnect the motor coils when the driver is powered, this can destroy the driver.

This driver produces heat and has thermal shutdown protection. If the motor seems to lose steps it could be that the driver is overheating. It is recommended to use a fan to cool the drivers if this occurs.

**Selection Guide:**

**KTA-263**

---

1: 1 Driver per Board  
 2: 2 Drivers per Board  
 3: 3 Drivers per Board

---

A: Horizontal Plug-In Connectors  
 B: Vertical Plug-In Connectors (Available on Request)  
 C: No Connectors (Available on Request)

---