

Possible Applications

Multiple LonWorks Devices connected to one PLC

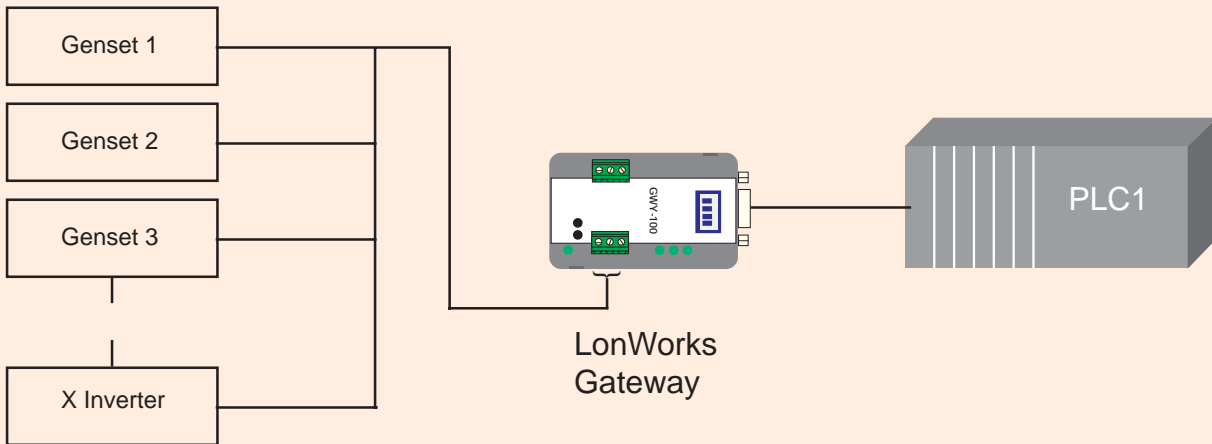

Multiple LonWorks Devices connected to Modbus Host

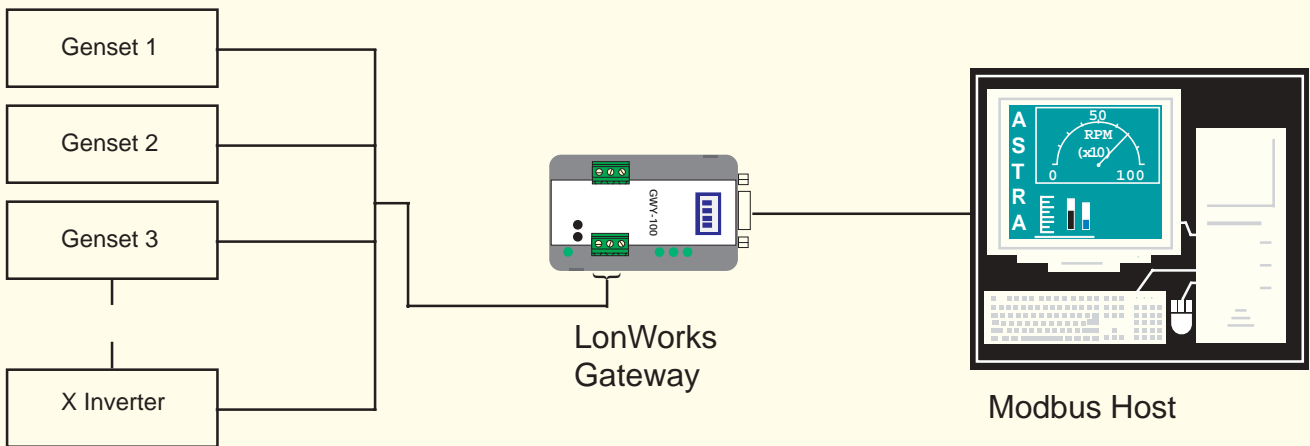

Multiple LonWorks Networks and multiple LonWorks Gateways

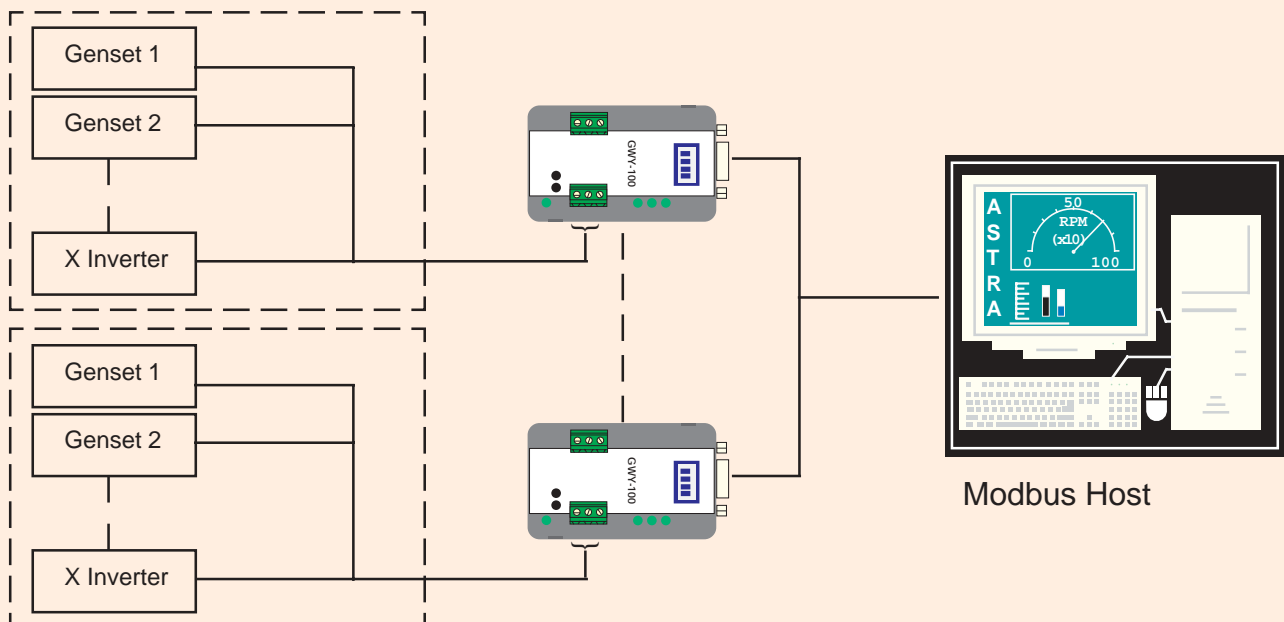

● Basic LonWorks Gateway Operation

The LonWorks Gateway communicates between LonWorks network interface on one side and various serial protocols on the other side (e.g. Modbus ASCII / RTU etc.). It allows LonWorks devices to make available their LonWorks variables for PLC's or SCADA. It also makes possible for serial device to act as a LonWorks node.

It is externally powered from 3 pin terminal block and power is isolated from both communication ports. Both the communication ports are also isolated from each-other.

Microsoft Windows® based configuration software, Gateway Setup, helps user to configure Gateway unit. 'Configuration' means making the Gateway unit work as per the system requirements. The complete configuration for a unit is termed as 'Project'. Project comprises of device names, Register addresses, Conditions for block execution etc.

Block may contain information like copy number of Words, Bits etc. from one device to other device and conditions for copy, if any. Gateway transfers data between two devices by execution of blocks.

After the Project is defined, Drivers for required devices and Project should be downloaded. Gateway can now communicate with the connected devices and transfers data between them.

System requirements for Gateway Setup Software are:

Windows Version :	Microsoft Windows 9x/NT/2000/XP
Processor :	PENTIUM or higher
Hard disk Space :	5 MB or more
Mouse :	Required
RAM :	16 MB or more
Display resolution:	800 X 600 (VGA) or better
Display colors :	16 bit color

Other Accessories required for the Gateway configuration:

1. Gateway unit
2. Gateway Configuration Cable
3. Gateway Setup Software
4. Devices with communication cables
5. Network Management Tool (Lonmaker) for installation of a node and binding of network variables

● Communication Ports

GWY-100 has two communication ports COM1 and COM2. COM1 port is compatible to RS232C / RS422 / RS485 and CMOS signal levels. Pin-out of these ports are as shown below :

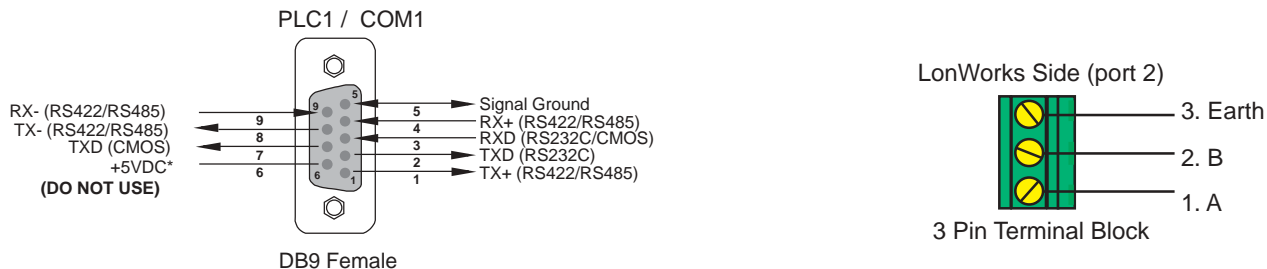

*Do not use pin no. 6 of PLC1 / COM1.

**Refer our website (www.renuelectronics.com) for your specific Cable requirements

● Switch Settings

There are 4 switches which decide,

- | | |
|---------------|---|
| Switch 1. | IBM Download |
| Switch 2,3,4. | Specific Template Selection (if applicable) |

● LED Status

Service LED:

- Flashing: Node has application but is not installed in the network. (Unconfigured node)
- Solid: Node is unconfigured and applicationless. Indicates errors detected by the neuron self test routine
- OFF: Node is configured and installed in the network.

OK LED:

- Flashing: IBM Download mode
- Solid: PLC Communication OK
- OFF: No firmware

LON LED:

- Flashing: Receiving frames from LonWorks network

PLC1 LED:

- Flashing: Receiving frames from PLC1 Port

Specifications

Power	: 12 V DC to 32 V DC, 1.6 W
LED's	: 3 LED's for status indication and 1 LED for device configuration status
Communication Ports	: 2 Communication ports with
COM1	: RS232 / RS422 / RS485 / CMOS
COM2	: LonWorks Network Interface. TP FT-10 (78 Kbps, free topology)
<i>(Isolation between communication ports and Power supply, through DC-DC coupler is 1 KV)</i>	
COM1 / PLC1	: Connects to PC for setup download or connects to PLC1 at runtime.
COM2 / PLC2	: LonWorks Network Interface. TP FT-10 (78 Kbps, free topology)
<i>(Isolation between communication ports, through opto-isolation is 1KV rms for 1 min)</i>	
Temperature	: Operating : 0° to 60°C Storage : -20° to 80°C
Humidity	: 10% to 90% (Non condensing)
Mounting	: DIN rail or back panel mounting
Dimensions (DIN rail)	: 105mm(L) X 40mm(D) X 51mm(W)
Weight	: 125 gm approx.
Certifications	: CE with UL certification
Immunity to ESD	: Level 3 as per IEC1000-4-2
Immunity to Transients	: Level 3 as per IEC1000-4-4
Immunity to Radiated RF	: Level 3 as per IEC1000-4-3
Immunity to Conducted RF	: Level 3 as per IEC1000-4-6
Emissions	: EN55011 CISPR A

Models

Series/Model	Technology	Protocol
GWY-00 *	Serial	Various
GWY-100 *	LonWorks	LonTalk
GWY-200 **	CANBus	DeviceNet
GWY-300 *	CANBus	CAN
GWY-400 *	USB	Various
GWY-500 **	Profibus	Profibus
GWY-600 #	Ethernet	Various

* Released

** Coming soon.

Contact Factory

Note: Contact factory for customized LonWorks Gateway applications (UNVT Templates).

Dimensions

GWY-100 unit is shipped with a separate DIN rail plate which has to be attached to the unit, if needed. User can use the unit with or without the DIN rail plate. Following sketch shows dimensional details of GWY-100 with the DIN rail plate.

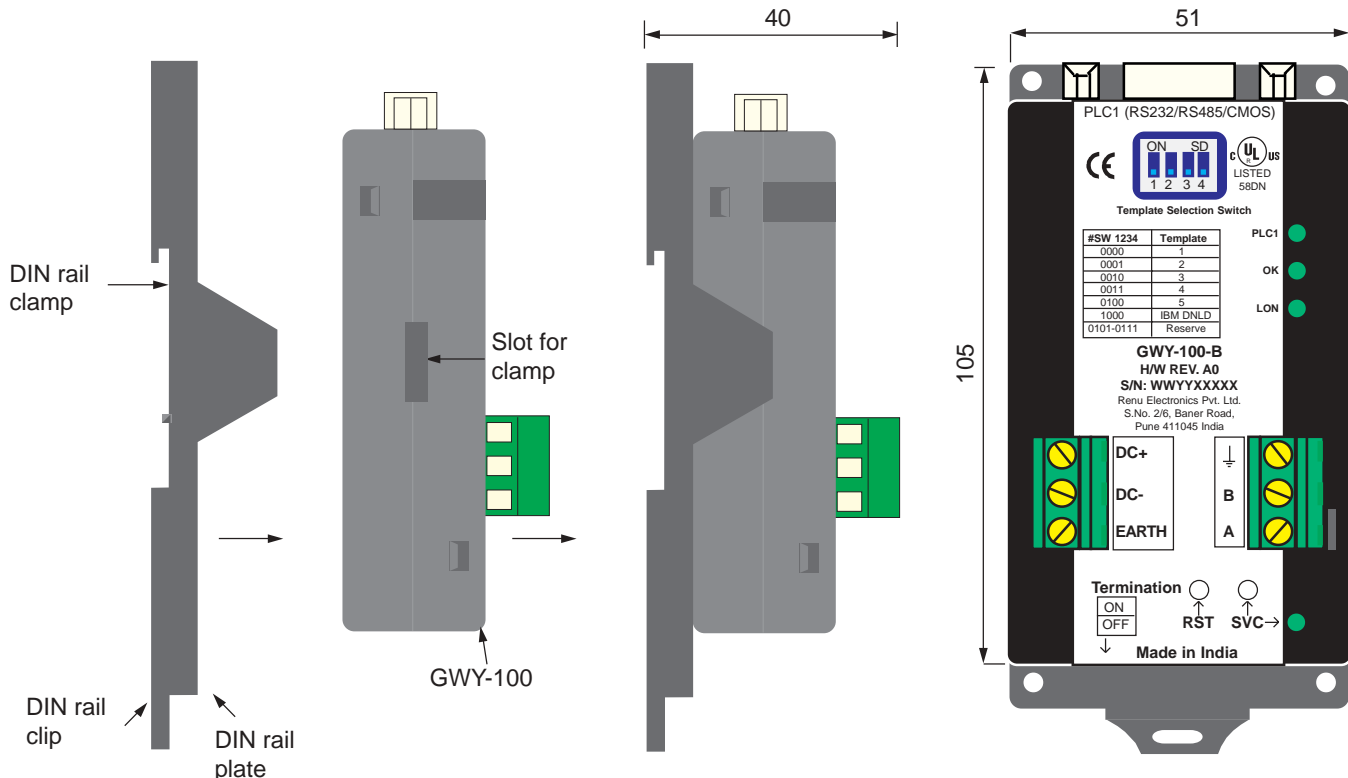

● PLC's Supported

The GWY-100 currently supports Modbus Slave (ASCII / RTU) and Toshiba inverter protocols. GWY-100 can also support following PLC's:

• ABB	• AB DF1 Full Duplex (Micrologix / SLC5/0x / PLC5/30)
• AB DH485 (SLC5 / 0x series)	• Aromat FP0 / FP1 / FP2 / FP Sigma and FPM
• Baldor Drives	• Calisto (Morgan Schaffer)
• Cegelec Alspa series	• Crouzet
• Delta DVP Series	• Discovery Panel
• Entertron	• GE Fanuc Series 90-30, VersaMax
• Honeywell	• Idec Micro 1 / FA2Jr PLCs
• IDEC Micro ³ / C, IDEC MicroSMART, IDEC Open Net	• J-BUS
• K1339_Slave	• Keyence KV
• Koyo	• LG MasterK 80S-300S
• Messung XMP-8 / NEXGEN 4000 / NEXGEN 5000	• METTLER TOLEDO Weighing Scales
• Mitsubishi FX	• Moisture Analyzer (Alpha Moisture Systems)
• Omron NT Link, Omron Host Link	• RHEONIC Mass Flowmeter
• SARTORIOUS Weighing Scales	• Siemens-S7-200 Series
• Siemens S7-300 Series	• Taian TP02 Series
• Telemecanique 17, 47 & 67 Series	• Telemecanique TSX07/37/57
• Toshiba T series (Programming Port)	• Twido
• USS Protocol	• Yaskawa Drives

GWY-100 can communicate with all the above PLC's using different communication cables. For detailed information on Gateway, visit our Website: www.renuelectronics.com or contact factory.

New PLC drivers are constantly added. Please contact factory for more information. We welcome an opportunity to develop new, custom drivers and customization of Gateway products.



Factory:

Renu Electronics Pvt Ltd.
 S.No. 2/6, Baner Road,
 Pune 411045, India.
 Tel: + 91 20 2729 2840, Fax: + 91 20 2729 2839
 Email: info@renuelectronics.com
 Website: www.renuelectronics.com

